

M1 Tip-up Seat

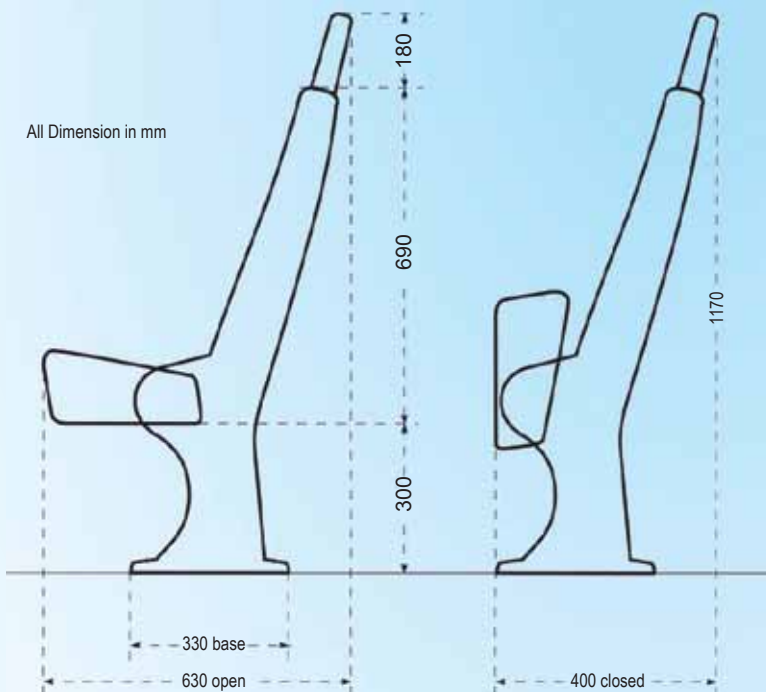

This seat compliments our semi high back and high back range in appearance and is a practical solution where space is at a premium. This seat has satisfied the strength and anchorage position requirements of 76/115/EEC and amended by 96/38/EC for M1 loading when mounted on a steel plate.

- Available in either semi high back or high back
- Various width options
- Choice of Fabrics and piping
- Fitted with either lap and diagonal or all age belt
- Forward or rear facing options
- Extensive accessories available.
- Certificate of conformity



Approved by:



Bulkhead Tip-up Seat

A compact but comfortable seat for occasional use. Well designed for bulkhead/body mounting with a spring assisted seat return.



- Height 620 mm to 1000mm
- Available 400 to 430mm wide
- Choice of Fabrics and piping
- Option of either lap belt or lap & diagonal
- Concealed mounting points
- Designed for rear facing installation
- Floor fixing frame available



Approved by:



M1 High Back Seat

This seat is a derivative of our very popular semi-high back range providing additional Comfort within its styled contour shape. The seat has satisfied the strength and anchorage positional requirements of 76/115/EEC as amended by 96/38/EC for M1 loading* when mounted on a steel plate.

- *Available in double and treble format to M2 loading.
- Fitted with either integral lap and diagonal or all age belts.
- Choice of fabrics and piping.
- Alternative width and height options.
- Legs accept various quick release fittings.
- Extensive accessory range.
- Certificate of conformity



All Dimension in mm

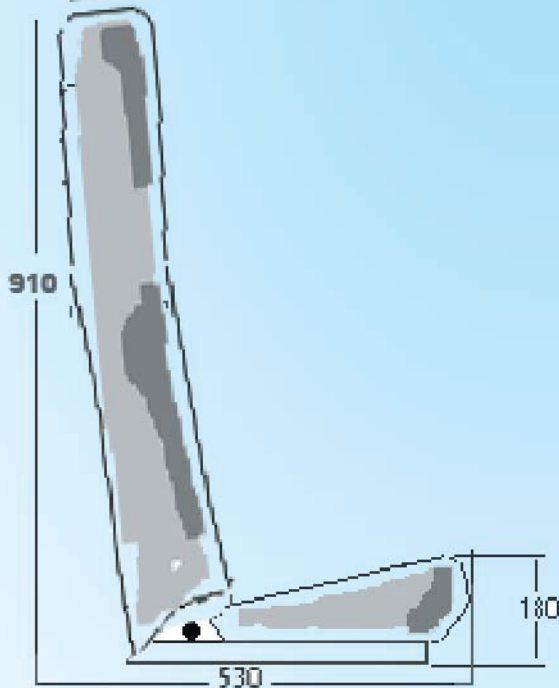

Approved by:



M1 Semi-high back seat

The most popular seat in our range combining comfort and durability with style. The seat has satisfied the strength and anchorage positional requirements of 76/115/EEC as amended by 96/38/EC for M1 loading* when mounted on a steel plate.



- *Available in double and treble format to M2 loading.
- Fitted with either lap and diagonal or all age belts.
- Choice of fabrics and piping.
- Alternative width and height options.
- Legs accept various quick release fittings.
- Extensive accessory range.
- Certificate of conformity

All Dimension in mm

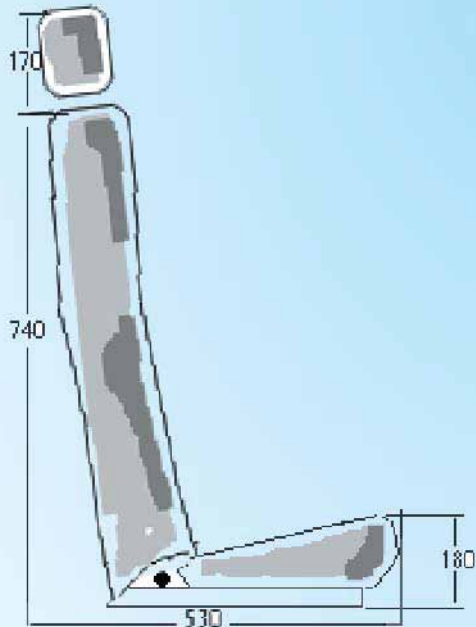

Approved by:



Tip & Fold Seat (MK 2)

This compact seat has been specifically designed for use in wheelchair accessible vehicles, folding away in a minimum area allowing maximum gangway space for access. The seat has satisfied the strength and anchorage positional requirements of 76/115/EEC as amended by 96/38/EC for M1 loading when mounted on a steel plate.



- Fitted with either integral lap and diagonal or all age belts.
- Choice of fabrics and piping.
- Height variation to suit all wheel arch types.
- Extensive accessory range.
- Simple operating mechanism to suit offside or nearside installation.
- Certificate of conformity



Approved by:



Accessory range



Moulded Headrest



Grab Handle with trimmed headrest



Armrest



Footrest



Allage Belt



ABS Back

Approved by:

